

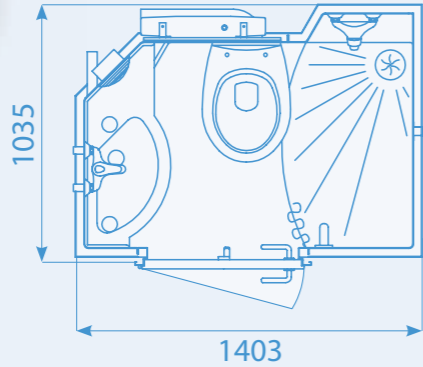

ONYX

The solution for small spaces

- Floor surface required : 1,45 m²
- Refurbishment clearance : 1900 x 700 mm



GALÈNE

Designed to be installed in corners which frees up space !

- Floor surface required : 1,70 m²
- Refurbishment clearance : 1900 x 700 mm

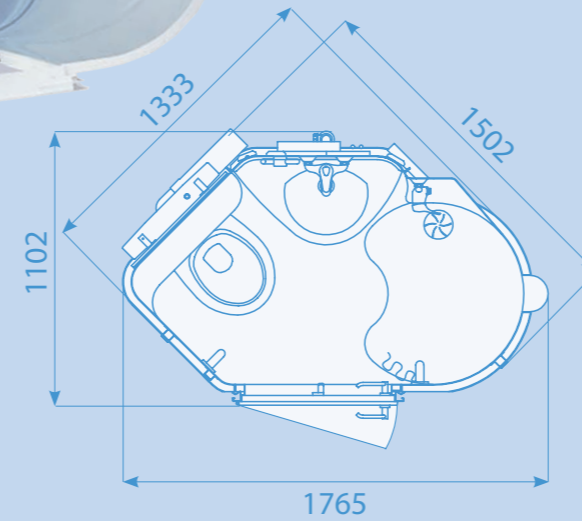

JADE

A compact solution for a restricted space

- Floor surface required : 1,45 m²
- Refurbishment clearance : 1051 x 841 mm

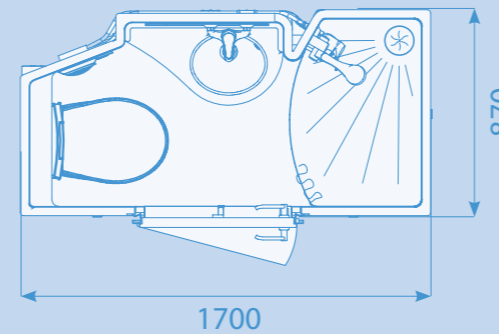

PYRITE

The complete shower space

- Floor surface required : 1,40 m²
- Refurbishment clearance : 1900 x 700 mm

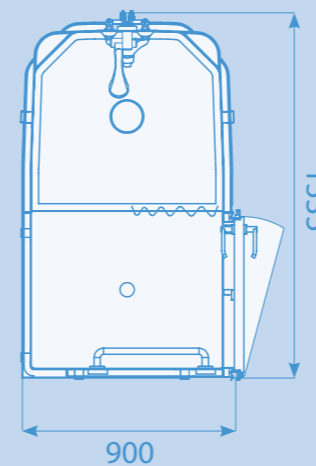
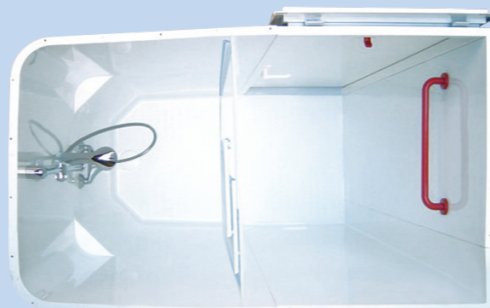

JASPE

Comfort and convenience in one design

- Floor surface required : 2,55 m²
- Refurbishment clearance : 1900 x 800 mm

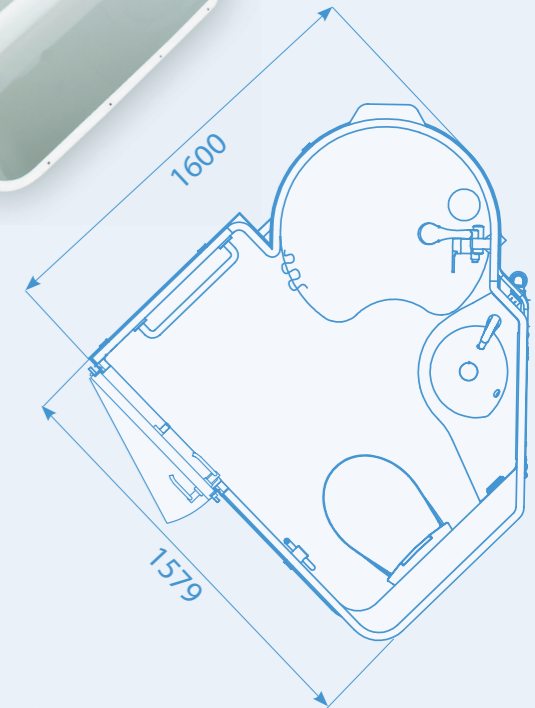

QUARTZ

The best space/price value (double-shell model)

- Floor surface required : 1,60 m²
- Refurbishment clearance : 1900 x 700 mm

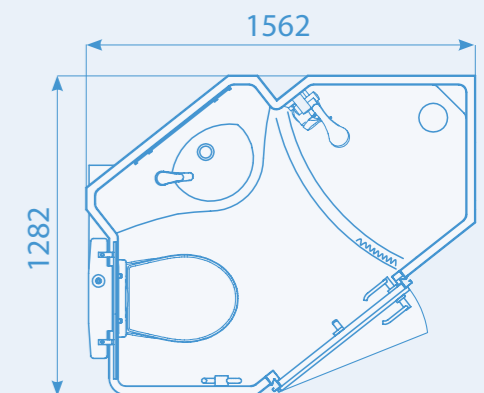

PERLE

Compact and practical

- Floor surface required : 1,70 m²
- Refurbishment clearance : 1900 x 700 mm

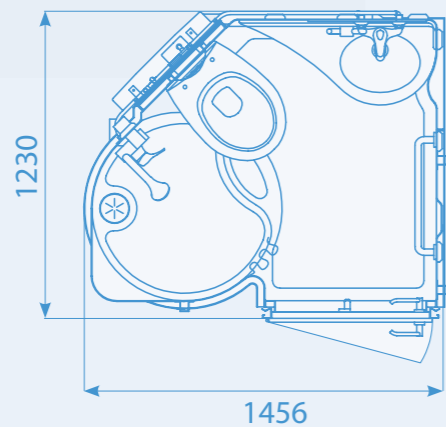

References

OUR CLIENTS INCLUDE :

- ACCOR GROUP
- ARDMORE
- BOUYGUES
- CARILLION
- DERWENT LIVING
- J COFFEY CONSTRUCTION
- KIER GROUP
- LAING O'ROURKE
- LAND SECURITIES
- LIBERTY LIVING
- MANSELL
- MILLER CONSTRUCTION
- MORGAN ASHURST (Bluestone)
- PRIORY GROUP
- PROVIAN CONSTRUCTION
- SANCTUARY HOUSING
- SCOUT ASSOCIATION
- SHARPLES
- SHEPHERD CONSTRUCTION
- THOMAS FISH
- YMCA

INSTALLATIONS INCLUDE :

- ASTON UNIVERSITY
- BIRMINGHAM UNIVERSITY
- CAMBRIDGE UNIVERSITY
- CENTRAL LANCASHIRE UNIVERSITY
- DE MONTFORT UNIVERSITY LEICESTER
- DE MONTFORT UNIVERSITY BEDFORD
- DERBY UNIVERSITY
- DURHAM UNIVERSITY
- GLASGOW UNIVERSITY
- GREENWICH UNIVERSITY
- HERTFORDSHIRE UNIVERSITY
- IMPERIAL COLLEGE OF LONDON
- KINGSTON UNIVERSITY
- LEEDS UNIVERSITY
- MANCHESTER UNIVERSITY
- NOTTINGHAM TRENT UNIVERSITY
- OXFORD UNIVERSITY
- QUEEN MARGARET UNIVERSITY EDINBURGH
- ROYAL VETERINARY COLLEGE, LONDON
- ST MARY'S UNIVERSITY
- SWANSEA UNIVERSITY

- IBIS HOTEL
- ETAP HOTEL
- OXFORD NIGHT SHELTER
- OXFORD HOTEL, LONDON
- STYLOTEL, LONDON
- SUITE HOTEL

FRANCE

- CITÉ UNIVERSITAIRE ANTINEA à LA ROCHELLE
- CITÉ UNIVERSITAIRE DE RANGEUIL à TOULOUSE
- CITÉ UNIVERSITAIRE VOIE DOMITIENNE à MONTPELLIER
- CITÉ UNIVERSITAIRE DE VERT BOIS à MONTPELLIER
- CITÉ UNIVERSITAIRE FRESCHÉ BLANC à NANTES
- CITÉ UNIVERSITAIRE P3 ET P4 à NANCY
- CITÉ UNIVERSITAIRE LES HÊTRES à ORLÉANS
- MAISON DES PROVINCES DE FRANCE à PARIS
- CENTRE DE VACANCES JEAN FRANCO à CHAMONIX
- CONGREGATION RELIGIEUSE JEAN BOSCO à LYON
- FOYERS AMITEL à STRASBOURG
- FOYER DE JEUNES TRAVAILLEURS à ARGENTEUIL
- HÔTEL FLOREL à BESANÇON
- ETAP*HOTEL
- FAST*HOTEL
- HOTEL PREMIERE CLASSE
- HÔTEL FLOREL à BESANÇON
- IBIS HOTEL
- NUIT D'HÔTEL
- SUITE HÔTEL
- BASE AÉRIENNE 105 à EVREUX
- BONBONS HARIBO
- CENTRE DE FORMATION POLICE à NICE
- GENDARMERIE QUARTIER LARIBOISIÈRE à FONTAINEBLEAU
- ECOLE NATIONALE DE POLICE à NÎMES

- MILITARY SCHOOL ST. CYR
- U.C.P.A.

GERMANY

- IBIS HOTEL Berlin
- IBIS HOTEL Hambourg
- IBIS HOTEL Hanovre
- IBIS HOTEL Köln Airport
- IBIS HOTEL Munster
- IBIS HOTEL Stuttgart
- SUITE HOTEL Berlin
- SUITE HOTEL Hambourg
- SUITE HOTEL Munich Schwabing
- SUITE HOTEL Vienne

SPAIN

- IBIS HOTEL Alicante
- IBIS HOTEL Meridiana Barcelone
- IBIS HOTEL Murcia
- IBIS HOTEL Saragoza
- IBIS HOTEL Salamanca
- IBIS HOTEL Valencia Manises

BELGIUM

- CENTRE HOSPITALIER de HUY
- CPAS CHARLEROI à MARCHIENNE AU PONT
- DOMAINE DE LA VERTEFEUILLE à TOURNAI
- FOYER DE PROVIDENCE à BEAUFAYS
- INSTITUT ST THOMAS DE VILLENEUVE à LUSTIN PROFONDEVILLE
- MAISON DE RETRAITE BELOEIL à HENRI CHAPELLE
- MAISON DE RETRAITE LA VISITATION à LOBBES
- MAISON DE RETRAITE PANNESHEYDT à MONTZEN
- MAISON DE REPOS REGINA à MORESNET
- MAISON DE RETRAITE LA STE FAMILLE à ROUVROY
- RESIDENCE DU CHEMIN DE LONCIN à ANS

The Utility Range

This extensive range is both functional and highly economical, ideally suited to a variety of applications including university halls of residence, youth hostels, key worker accomodation, hostels and MOD residences.

Attractively designed and deceptively spacious, these bathroom units combine a durable composite structure, with easy installation saving on labour and maintenance costs. Available for new build and refurbishment.

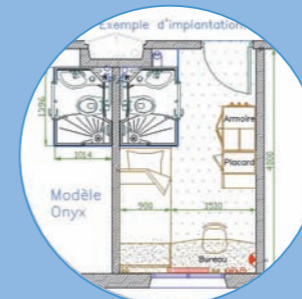

Offsite pods onsite solutions



Mercury House / The Courtyard
Roman Way / Coleshill
Warwickshire / B46 1HQ
T. : 01675 463810
F. : 01675 465467
www.baudet-uk.com
Email : sales@baudet-uk.com

